

# Trus<T>Lift Trouble Shooting Manual- SECTE026 + WMBTE006

Lift Description: Trus<T>Lift- All Travel Heights- Upper and Lower Interlocks-Emergency Bell Pack (Bell Pack may be eliminated in certain applications)

## Introduction

### Trus<T>Lift Component Description/Location

When using this manual, reference will be made to components which contain the wires and/or terminal you will measure voltage and/or resistance at. Figure 1 shows the different locations on the lift; they include:

- A- Main Control Panel \* Located on front side of unit (not pictured)
- B- Outside Junction Box
- C- Upper Interlock
- D- Lower Interlock
- E- Call Station

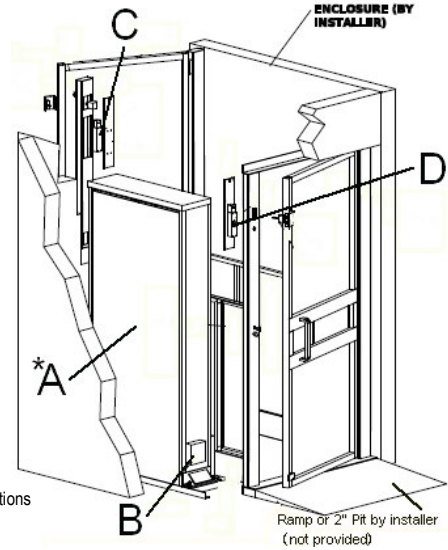

Figure 1: Typical Layout with Lift Locations

Within the Main control panel there are different locations which may be referred to as test points, they are listed below and shown in Figure 2 and 3.

- a. M1 Relay (Down)
- b. M2 Relay (Up)
- c. M3 Relay (Main)
- d. Terminal Strip
- e. Fuse Location
- f. Field Wiring
- g. Push Button Contacts
- h. Emergency Stop
- i. Ground Lug
- j. On/Off Key Switch
- k. Serial Number

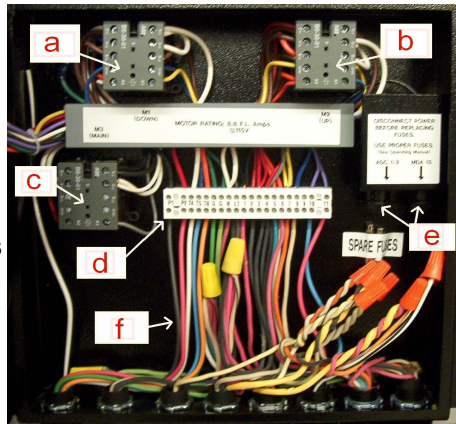

Figure 2: Main Control Panel - Inside View

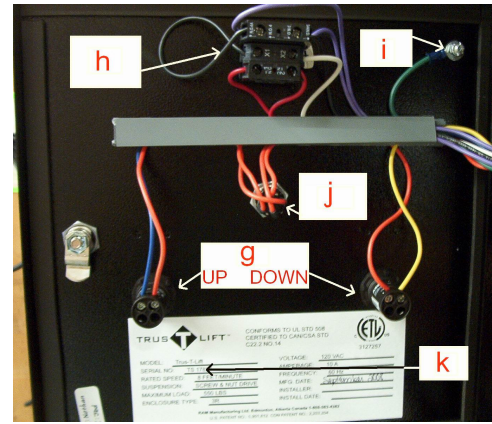

Figure 3: Main Control Panel Door - Inside View

When using this manual, reference will be made to limit switches located on the guide frame which will contain wires and/or terminals you will measure voltage and/or resistance at. The pictures in Figure 4 below show the different locations on the lift that you will find behind the plastic tower cover.

- 1. Limit Switch Tube
- 2. Upper Limit Switch Plate
- 3. Bypass Limit Switch
- 4. Upper Limit Switch
- 5. Upper Final Limit Switch
- 6. Lower Limit Switch
- 7. Lower Bypass Plate
- 8. Drive Nuts
- 9. Lower Mechanical Stops (not on this unit)

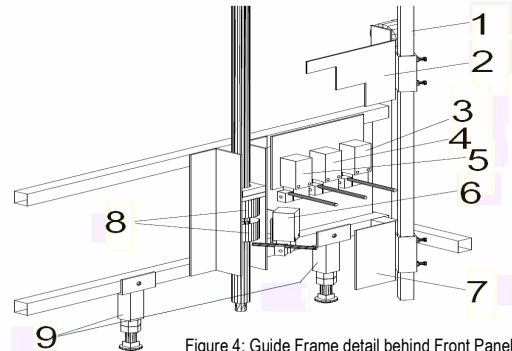

Figure 4: Guide Frame detail behind Front Panel

## Using a Volt Meter

When using this manual you will need a volt meter capable of reading AC (~) voltage as well as electrical resistance ( $\Omega$ ).

To measure voltage, touch the **black probe**, coming from the COM port on the volt meter, **to a ground terminal, ground lug or any grounded metal screw or bolt on the lift frame**. Touch the **red probe** coming from the V/  $\Omega$  port of the meter to "hot" points on the lift. See the example in Figure 5 and 6.



Figure 5: Proper Use of Volt meter

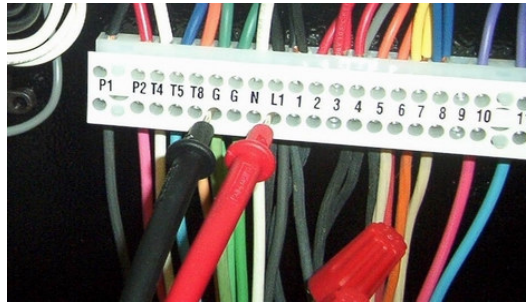

Figure 6: Note the black lead on ground and the red lead measuring voltage

## How to use this manual- READ THIS FIRST BEFORE PROCEEDING!

Follow through each section in chronological order, starting with Quick Trouble Shooting Guide thru to Trouble Shooting Section 3. The sections are titled as follows:

**Quick Trouble Shooting Guide**- Stop here first- this covers the most common problems solved quickly and easily.

**Trouble Shooting Section 1**- Lift will not move with main controls

**Trouble Shooting Section 2**- This section has responses for results found in Trouble Shooting Section 1

**Trouble Shooting Section 3**- This section has responses for results found in Quick Trouble Shooting Guide

**Appendix A**- Parts Breakdown drawing of complete lift and options

**Appendix B**- Limit Switch Activation Description

Working thru the manual in sequence is the most efficient and quickest method of trouble shooting your lift. **DO NOT** try and jump ahead as each step is important in properly diagnosing where the problem exists. Each step contains a procedure or function test. Perform the function test and then answer the question (Q) Take the next step according to the instructions that follow the correct answer.

## Quick Trouble Shooting Guide

This section provides some quick tips for things to test and check prior to getting too involved with the trouble shooting process. By checking a few things here you can jump ahead in the manual to save some time.

1. **Q-** Is the lift a new installation but not running after unpacking all of the components? **No-** Proceed to **Trouble Shooting Section 1. Yes-** Hook up all the field components to the lift (both the upper and lower interlocks) and then try running the unit. Note: you can make temporary connections at this point prior to running all the field wires in conduit. This will allow you to run the lift during the install
2. **Q-** Does the lift move in the up direction but not in the down direction? **Yes,** go to **Trouble Shooting Section 1, Step # 20, No** go to next step
3. **Q-** Does the lift move in the down direction but not in the up direction? **Yes,** go to **Trouble Shooting Section 1, Step # 13, No** go to next step
4. **Q-** Does the lift run but stop after traveling about 2" from either landing? **No,** proceed to next step, **Yes,** proceed to **Trouble Shooting Section 3, Lift moves 2" away from landing and stops.**
5. **Q-** Does the lift run past the landing when using the remote call stations? **No,** proceed to next step, **Yes,** proceed to **Trouble Shooting Section 3, Lift moves past landing when using call stations.**
6. **Q-** When the up or down button is depressed does the motor make a running noise or sound like it is attempting to run but the lift does not move? **No,** proceed to **Trouble Shooting Section 1, Yes** proceed to **Trouble Shooting Section 3, Motor makes a noise but the lift does not move**

## Trouble Shooting- Section 1

### Lift will not move with main controls

1. Open the main control panel
2. Test for voltage at L1 on the terminal strip, **Q-** Do you read 110-120 volts on your meter? **Yes** proceed to next step, **No** go to **Trouble Shooting Section 2- No Voltage at L1**
3. Test for voltage at #1 on the terminal strip, **Q-** Do you read 110-120 volts on your meter? **Yes** proceed to next step, **No** go to **Trouble Shooting Section 2- No voltage at #1**
4. Test for voltage at #2 on the terminal strip, **Q-** Do you read 110-120 volts on your meter? **Yes** proceed to next step, **No** go to **Trouble Shooting Section 2- No voltage at #2**
5. Test for voltage at #3 on the terminal strip, **Q-** Do you read 110-120 volts on your meter? **Yes** proceed to next step, **No** check to make sure the emergency stop button is not pushed in, if button is pushed in pull out and retest unit. **Q-** Does the lift run? **No** go to **Trouble Shooting Section 2- No voltage at #3**
6. Slowly remove the ½ Amp fuse by pushing up and CCW on the fuse holder while watching the M3 relay. **Q-** When the fuse is slowly pulled out does the M3 relay make a "click" sound? **Yes-** replace fuse holder and go to **Step 10, No** go to next step
7. Check for voltage across M3 A1 (red lead from the meter) and M3 A2 (black lead from the meter), **Q-** Do you read 110-120 volts on your meter? **Yes** proceed to next step, **No** go to **Step 9**
8. Disconnect power from the lift and replace the M3 relay. Once replaced restore power to the unit and test unit. If the lift does not run go to **Step 5**
9. Disconnect power from the lift. There must be a loose wire going from either terminal block 3 to M3 A1 or from M3 A2 to M2 A2 or M2 A2 to M1 A2. Repair or replace as necessary, restore power to the unit and test unit for operation. **Q-** Does the lift run? **No-** go to **Step 7**
10. Test for voltage at #4 on the terminal strip, **Q-** Do you read 110-120 volts on your meter? **Yes** proceed to next step, **No** go to **Trouble Shooting Section 2- No voltage at #4**
11. The next steps will attempt to move the lift in the down direction, to attempt at moving the lift in the up direction go to **Step 19**
12. While depressing the down paddle test for voltage at #5 on the terminal strip, **Q-** Do you read 110-120 volts on your meter? **Yes** proceed to next step, **No** go to **Trouble Shooting Section 2- No voltage at #5**
13. While depressing the down paddle test for voltage at #7 on the terminal strip, **Q-** Do you read 110-120 volts on your meter? **Yes** proceed to next step, **No** go to **Trouble Shooting Section 2- No voltage at #7**
14. While depressing the down paddle test for voltage at M2 21 on the M2 Relay, **Q-** Do you read 110-120 volts on your meter? **Yes** proceed to next step, **No** go to **Trouble Shooting Section 2- No voltage at M2 21**
15. While depressing the down paddle test for voltage at M2 22 on the M2 Relay, **Q-** Do you read 110-120 volts on your meter? **Yes** proceed to next step, **No** go to **Trouble Shooting Section 2- No voltage at M2 22**

16. While depressing the down paddle test for voltage at M1 A1 on the M1 Relay, **Q-** Do you read 110-120 volts on your meter? **Yes** proceed to next step, **No** go to **Trouble Shooting Section 2- No voltage at M1 A1**
17. For this step place the black lead from your meter on M1 A2. While depressing the down paddle test for voltage at M1 A1 on the M1 Relay, **Q-** Do you read 110-120 volts on your meter? **Yes** proceed to next step, **No** go to **Trouble Shooting Section 2- No voltage at M1 A1 and M1 A2**
18. Disconnect power from the lift and replace the M1 relay. Once replaced restore power to the unit and test unit in down direction. If the lift does not run go to **Step 2**, if lift does go down test up direction, if lift does not go up go to next step
19. While depressing the up paddle test for voltage at #6 on the terminal strip, **Q-** Do you read 110-120 volts on your meter? **Yes** proceed to next step, **No** go to **Trouble Shooting Section 2- No voltage at #6**
20. While depressing the up paddle test for voltage at #8 on the terminal strip, **Q-** Do you read 110-120 volts on your meter? **Yes** proceed to next step, **No** go to **Trouble Shooting Section 2- No voltage at #8**
21. While depressing the up paddle test for voltage at M1 21 on the M1 Relay, **Q-** Do you read 110-120 volts on your meter? **Yes** proceed to next step, **No** go to **Trouble Shooting Section 2- No voltage at M1 21**
22. While depressing the up paddle test for voltage at M1 22 on the M1 Relay, **Q-** Do you read 110-120 volts on your meter? **Yes** proceed to next step, **No** go to **Trouble Shooting Section 2- No voltage at M1 22**
23. While depressing the up paddle test for voltage at M2 A1 on the M2 Relay, **Q-** Do you read 110-120 volts on your meter? **Yes** proceed to next step, **No** go to **Trouble Shooting Section 2- No voltage at M2 A1**
24. For this step place the black lead from your meter on M2 A2. While depressing the up paddle test for voltage at M2 A1 on the M2 Relay, **Q-** Do you read 110-120 volts on your meter? **Yes** proceed to next step, **No** go to **Trouble Shooting Section 2- No voltage at M2 A1 and M2 A2**
25. Disconnect power from the lift and replace the M2 relay. Once replaced restore power to the unit and test unit in up direction. If the lift does not run go to **Step 2**, if lift does go up test down direction, if lift does not go down go to **Step 13**.

## Trouble Shooting- Section 2

### No Voltage at L1

Problem: No power is coming into the lift.

1. Verify the unit is plugged into a main power source. Is the unit plugged in? **Yes-** proceed to next step, **No-** plug unit into wall and test unit. **Q-** Does the lift run? **No-** Go to the next step
2. Test voltage at outlet or power source, **Q-** Do you read 110-120 volts on your meter? **Yes** proceed to next step, **No** – the outlet or power supply has a fault, check the breaker on the main panel servicing the outlet or call an electrician to repair outlet
3. Inspect the power cord (14-3 cable) running from the outlet or disconnect (depends on the install) to the inside of the control box. Make sure there are good connections for the wires inside the control box at the terminal strip. Also make sure the cable or plug isn't damaged- repair or replace as necessary and test the unit. **Q-** Does the lift run? **No** go to **Trouble Shooting Section 1, Step #2**

### No Voltage at #1

Problem: Power is present in the lift but not beyond the fuses.

1. Unplug the unit and set volt meter to read OHMS or resistance ( $\Omega$ )
2. Remove both fuses by pushing up and turning counter clockwise on the fuse holders. Using the meter test resistance of each fuse. **Q-** Are the fuses good (have continuity)? **Yes** go to next step **No** go to step 4
3. There is a loose wire(s) between L1 on the terminal strip and both fuses or the wires to M3-L1 and 1 on the terminal strip. Repair or replace wires then restore power to the unit and test operation. **Q-** Does the lift run? **No** go to **Trouble Shooting Section 1, Step #3**
4. Replace fuse(s) with new, plug in the lift and test operation. **Q-** Does the lift run? **No-** repeat test of resistance on fuses, did they blow again? **Yes** go to next step **No** go to step 3 just above.
5. There is a short in the lift's electrical circuit, call an electrician or RAM Manufacturing for further assistance.

## No Voltage at #2

Problem: There is a fault in the electrical safety circuit which is wired between 1 and 2 on the terminal strip.

1. **Q-** Are both the upper and lower interlocks closed with the interlock in the locked position? **Yes-** proceed to next step, **No-** then close the doors and make sure the interlocks are in the locked position and test run the unit. **Q-** Does the lift run? **No** go to next step
2. In the main control box test for voltage at wire White with Black Stripe on cable 11 going to a bundle under a wire nut. **Q-** Do you read 110-120 volts on your meter? **Yes** proceed to next step, **No** then problem is with connections in the bundle or at terminal 1 on the terminal strip. Check wires and connections repairing as necessary, all 5 wires should be tightly connected. Test unit for operation **Q-** Does the lift run? **No-** go to **Trouble Shooting Section 1, Step #4**
3. Go to the outside junction box (*see Introduction for location*) on the bottom left side of the tower and remove cover
4. Test for voltage at the connection of Cable 11- White w/ Black stripe wire with the Blue wire from the upper interlock, **Q-** Do you read 110-120 volts on your meter? **Yes** proceed to next step **No** inspect 16-8 cable 11 running inside the tower from the main control box to the outside junction box for damage. Repair or replace as necessary and retest unit for operation. **Q-** Does the lift run? **No-** Go to **Step #2** above
5. Test for voltage at the connection of Upper Interlock Grey wire with the Lower Interlock blue wire, **Q-** Do you read 110-120 volts on your meter? **Yes** proceed to next step, **No** then check the upper gate is in the locked position and closed properly. The latch must be making good contact with the lock in order to function properly. If the gate is closed, locked and latched properly and lift does not run proceed to **Step #16** below
6. Test for voltage at the connection of Cable 10- Blue wire to the Grey wire from the lower interlock and Brown wire from the upper interlock, **Q-** Do you read 110-120 volts on your meter? **Yes-** Go to next step **No-** **No** then check the upper gate is in the locked position and closed properly. The latch must be making good contact with the lock in order to function properly. If the gate is closed, locked and latched properly and lift does not run proceed to **Step #24** below
7. Test for voltage at the connection of Upper Interlock white wire to Lower Interlock brown wire **Q-** Do you read 110-120 volts on your meter? **Yes** Go to next step; **No** Go to **Step #20** below.
8. Test for voltage at Cable 10 White wire to Lower Interlock white wire. **Q-** Do you read 110-120 volts on your meter? **Yes** Go to next step; **No** Go to **Step #27** below.
9. Go to the main control box
10. Test for voltage on the connection of Cable 10 White wire to Cable 4, Upper Final White wire **Q-** Do you read 110-120 volts on your meter? **Yes** go to next step **No**
11. Test for voltage at the connection of Cable 4, Upper Final to #2 at the terminal strip. **Q-** Do you read 110-120 volts on your meter? **No** Go to next step; **Yes** Go to **Trouble Shooting Section 1, Step #5**
12. Upper Final Limit switch circuit has a fault. **Q-** Remove the front panel, is the Upper Final Limit Switch activated? **No** proceed to next step, **Yes-** deactivate the upper final limit switch and test operation, if lift does not run proceed to next step.
13. Check the circuit for loose wires and/or a damaged cable. Remove the front cover to the Upper Final Limit Switch and check for good connections. Also verify good connection of the black wire from the upper final limit switch to #2 on the terminal strip. Repair or replace wires as necessary and retest unit. **Q-** Does the lift run? **No** proceed to next step
14. Disconnect power from the lift. Replace the Upper Final limit switch. Restore power to the lift and test operation, does the lift run? **No** go to **Trouble Shooting Section 1, Step #4**
15. Remove the red cover from the front of the Upper Interlock by removing the 4x Philips head screws, proceed to next step once complete
16. Be sure the latch for the interlock is into the interlock head, proceed to the next step.
17. Inside the interlock test for voltage at connection #41, **Q-** Do you read 110-120 volts on your meter? **Yes** proceed to next step, **No** inspect the interlock harness for damaged wires- the blue wire in the harness must be damaged. Repair or replace as necessary and retest unit. **Q-** Does the lift run? **No** proceed to **Trouble Shooting Section 1, Step #4**
18. Inside the interlock test for voltage at connection #42, **Q-** Do you read 110-120 volts on your meter? **Yes** proceed to **Step #5 within this section**, **No** then the interlock needs to be replaced. Replace interlock and retest unit **Q-** Does the lift run? **No** Go to **Trouble Shooting Section 1, Step #4**
19. Remove the red cover from the front of the Upper Interlock by removing the 4x Philips head screws, proceed to next step once complete
20. Be sure the latch for the interlock is into the interlock head, proceed to the next step.
21. Inside the interlock test for voltage at connection #11, **Q-** Do you read 110-120 volts on your meter? **Yes** proceed to next step, **No** inspect the interlock harness for damaged wires- the brown wire in the harness must be damaged. Repair or replace as necessary and retest unit. **Q-** Does the lift run? **No** proceed to **Trouble Shooting Section 1, Step #4**
22. Inside the interlock test for voltage at connection #12, **Q-** Do you read 110-120 volts on your meter? **Yes** proceed to **Step #5**, **No** then the interlock needs to be replaced. Replace interlock and retest unit, **Q-** Does the lift run? **No** Go to **Trouble Shooting Section 1, Step #4**
23. Remove the red cover from the front of the Lower Interlock by removing the 4x Philips head screws, proceed to next step once complete
24. Be sure the latch for the interlock is into the interlock head, proceed to the next step.

25. Inside the interlock test for voltage at connection #41, **Q-** Do you read 110-120 volts on your meter? **Yes** proceed to next step, **No** inspect the interlock harness for damaged wires- the blue wire in the harness must be damaged. Repair or replace as necessary and retest unit. **Q-** Does the lift run? **No** proceed to **Trouble Shooting Section 1, Step #4**
26. Inside the interlock test for voltage at connection #42, **Q-** Do you read 110-120 volts on your meter? **Yes** proceed to **Step #5 within this section**, **No** then the interlock needs to be replaced. Replace interlock and retest unit **Q-** Does the lift run? **No** Go to **Trouble Shooting Section 1, Step #4**
27. Remove the red cover from the front of the Lower Interlock by removing the 4x Philips head screws, proceed to next step once complete
28. Be sure the latch for the interlock is into the interlock head, proceed to the next step.
29. Inside the interlock test for voltage at connection #11, **Q-** Do you read 110-120 volts on your meter? **Yes** proceed to next step, **No** inspect the interlock harness for damaged wires- the brown wire in the harness must be damaged. Repair or replace as necessary and retest unit. **Q-** Does the lift run? **No** proceed to Trouble Shooting Section 1, Step #4
30. Inside the interlock test for voltage at connection #12, **Q-** Do you read 110-120 volts on your meter? **Yes** proceed to Step #5, **No** then the interlock needs to be replaced. Replace interlock and retest unit, **Q-** Does the lift run? **No** proceed to Trouble Shooting Section 1, Step #4

### **No Voltage at #3**

Problem: There is a fault in the Emergency Stop circuit which is wired between 2 and 3 on the terminal strip

1. Emergency stop circuit has a fault- Disconnect power to the unit and inspect the emergency stop wiring for loose or damaged wires. Replace or repair as necessary. If wires are ok replace the emergency stop button and contact. Restore power to the unit and test operation of the lift- **Q-** does the lift run? **No** go to **Trouble Shooting Section 1 Step #5**

### **No Voltage at #4**

Problem: There is a fault in wire between 3 and 4 on the terminal strip

1. Disconnect power to the unit and check in control box for a grey wire jumping from the top of #3 on the terminal strip to the top of #4 on the terminal strip, this wire must be loose or broken. Replace or repair as necessary. Restore power to the unit and test operation of the lift- **Q-** does the lift run? **No** go to **Trouble Shooting Section 1, Step #10**

### **No Voltage at #5**

Problem: There is a fault in the Lower push button circuit which is wired between the emergency stop button and 5 on the terminal strip

1. On the door of the main control panel locate the emergency stop button. There is an orange wire that comes from the key switch and attaches to the emergency stop button. Measure for voltage at this point. **Q-** Do you read 110-120 volts on your meter? **No** go to **No Voltage at #3**, **Yes** go to **next step**
2. Is the silver key on the center of the control box door turned to the right (horizontal)? **Yes** go to the next step, **No**, then turn the key to the right and test the unit in the down direction, Does the lift run? **No**, go to **next step**. **Yes** go to **Trouble Shooting Section 1, Step #19**.
3. On the door of the main control panel locate the down contact button. There is an orange wire that comes from the key switch and attaches to the down contact. Measure for voltage at this point. **Q-** Do you read 110-120 volts on your meter? **No** go to next step, **Yes** go to **Step #6**
4. Problem exists with the key switch circuit. Check for loose wires on the key switch and going from the key to the down contact. **Q-** Are any wires loose or broken? **Yes** repair or replace as necessary and retest unit in the down direction. **Q-** Does the lift run? **No** go to next step. **Yes** go to **Trouble Shooting Section 1, Step #19**.
5. Problem exists with the key switch. Replace the key switch and retest the unit in the down direction, **Q-** does the lift run? **No** go to next step. **Yes** go to **Trouble Shooting Section 1, Step #19**.
6. **While depressing the down contact** measure for voltage on the back of the down contact where the yellow wire attaches. **Q-** Do you read 110-120 volts on your meter? **No** then down contact button is faulty- replace down contact and retest unit in down direction. **Q-** Does the lift run? **No** go to next step
7. Inspect the yellow wire running from the down contact to terminal block #5 for breakage or loose connections. Repair and replace as necessary. Retest unit in down direction- **Q-** does the lift run? **No** go to **Trouble shooting Section 1, Step #14**

### **No Voltage at #6**

Problem: There is a fault in the Upper push button circuit which is wired between the emergency stop button and 6 on the terminal strip

1. On the door of the main control panel locate the emergency stop button. There is an orange wire that comes from the key switch and attaches to the emergency stop button. Measure for voltage at this point. **Q-** Do you read 110-120 volts on your meter? **No** go to **No Voltage at #3, Yes** go to **next step**
2. Is the silver key on the center of the control box door turned to the right (horizontal)? **Yes** go to the next step, **No**, then turn the key to the right and test the unit in the down direction, Does the lift run? **No**, go to **next step. Yes** go to **Trouble Shooting Section 1, Step #11.**
3. On the door of the main control panel locate the up contact button. There is an orange wire that comes from the key switch and attaches to the up contact. Measure for voltage at this point. **Q-** Do you read 110-120 volts on your meter? **No** go to next step, **Yes** go to **Step #6**
4. Problem exists with the key switch circuit. Check for loose wires on the key switch and going from the key to the down contact. **Q-** Are any wires loose or broken? **Yes** repair or replace as necessary and retest unit in the up direction. **Q-** Does the lift run? **No** go to next step. **Yes** go to **Trouble Shooting Section 1, Step #11.**
5. Problem exists with the key switch. Replace the key switch and retest the unit in the up direction, **Q-** does the lift run? **No** go to next step. **Yes** go to **Trouble Shooting Section 1, Step #11.**
6. **While depressing the up contact** measure for voltage on the back of the up contact where the blue wire attaches. **Q-** Do you read 110-120 volts on your meter? **No** then up contact button is faulty- replace up contact and retest unit in up direction. **Q-** Does the lift run? **No** go to next step
7. Inspect the blue wire running from the up contact to terminal block #6 for breakage or loose connections. Repair and replace as necessary. Retest unit in up direction- **Q-** does the lift run? **No** go to **Trouble shooting Section 1, Step #21**

### No Voltage at #7

Problem: There is a fault in the Lower Limiting circuit which is wired between 5 and 7 on the terminal strip

1. **Q-** Is the lift at the bottom landing already? **No** proceed to next step, **Yes-** this is normal, if lift is at the bottom it will not travel down further, go to **Trouble Shooting Section 1, Step #19**
2. The lower limit switch circuit is at fault. Remove the front panel and inspect the lower limit switch, is it activated? **Yes** proceed to next step, **No** go to **Step #5**
3. If switch is activated by the lower drive nut and red safety bracket then this is normal. If a foreign object is activating the switch then remove and retry. **Q-** Does the lift run? **Yes** go to Trouble shooting Section 1, **Step #19, No** go to next step
4. Disconnect power from the lift. Check for good wire connections at 5 and 7 on the terminal strip. Also remove the cover panel on the front of the lower limit switch and check for good wire connections. **Q-** Are the connections good? **Yes** go to **Step #6, No** go to next step
5. Repair or replace wires at 5 and 7 on the terminal strip and/or inside the lower limit switch at points 21 and 22. Restore power to the lift and test operation. **Q-** Does the lift run? **Yes** go to Trouble shooting Section 1, **Step #19, No** go to next step
6. Disconnect power from the lift. Replace the lower limit switch. Restore power to the lift and test operation in the down direction. **Q-** Does the lift run? **Yes** go to Trouble shooting Section 1, **Step #19, No** go to Trouble shooting Section 1, **Step #5**

### No Voltage at #8

Problem: There is a fault in the Upper Limiting circuit which is wired between 6 and 8 on the terminal strip

1. **Q-** Is the lift at the top landing already? **No** proceed to next step, **Yes-** this is normal, if lift is at the top it will not travel up further, go to **Trouble Shooting Section 1, Step #11**
2. The upper limit switch circuit is at fault. Remove the front panel and inspect the upper limit switch, **Q-** is the upper limit switch it activated? **Yes** proceed to next step, **No** go to **Step #4**
3. If switch is activated on the upper limit switch bracket then this is normal. If you need to travel higher then adjust the bracket top allow it to do so. If a foreign object is activating the switch then remove and retry. **Q-** Does the lift run? **Yes** go to **Trouble shooting Section 1, Step #11, No** go to next step
4. Disconnect power from the lift. Check for good wire connections at 6 and 8 on the terminal strip. Also remove the cover panel on the front of the upper limit switch and check for good wire connections. **Q-** Are the connections good? **Yes** go to Step #6, **No** go to next step

5. Repair or replace wires at 6 and 8 on the terminal strip and/or inside the upper limit switch at points 21 and 22. Restore power to the lift and test operation. **Q-** Does the lift run? **Yes** go to **Trouble shooting Section 1, Step #11**, **No** go to next step
6. Disconnect power from the lift. Replace the upper limit switch. Restore power to the lift and test operation in the up direction. **Q-** Does the lift run? **Yes** go to **Trouble shooting Section 1, Step #11**, **No** go to **Trouble shooting Section 1, Step #5**

### **No voltage at M2 21**

1. Inspect the yellow wire running from the top of terminal block 7 to M2 21 for loose connections or damage. Repair or replace as necessary. Retest unit in the down direction. **Q-** Does the lift run? **No** go to **Trouble shooting Section 1, Step #14**

### **No voltage at M2 22**

1. Fault is with the N/C contact in the M2 relay. Replace the M2 relay and retest the unit in the down direction. **Q-** Does the lift run? **No** go to **Trouble shooting Section 1, Step #15**

### **No voltage at M1 A1**

1. Inspect the yellow wire running from M2 22 to M1 A1 for loose connections or damage. Repair or replace as necessary. Retest unit in the down direction. **Q-** Does the lift run? **No** go to **Trouble shooting Section 1, Step #16**

### **No voltage at M1 A1 and M1 A2**

1. Inspect the white wire running from terminal block N to M1 A2 for loose connections or damage. Repair or replace as necessary. Retest unit in the down direction. **Q-** Does the lift run? **No** go to **Trouble shooting Section 1, Step #17**

### **No voltage at M1 21**

1. Inspect the blue wire running from the top of terminal block 8 to M1 21 for loose connections or damage. Repair or replace as necessary. Retest unit in the up direction. **Q-** Does the lift run? **No** go to **Trouble shooting Section 1, Step #21**

### **No voltage at M1 22**

1. Fault is with the N/C contact in the M1 relay. Replace the M1 relay and retest the unit in the up direction. **Q-** Does the lift run? **No** go to **Trouble shooting Section 1, Step #22**

### **No voltage at M2 A1**

1. Inspect the blue wire running from M1 22 to M2 A1 for loose connections or damage. Repair or replace as necessary. Retest unit in the up direction. **Q-** Does the lift run? **No** go to **Trouble shooting Section 1, Step #23**

### **No voltage at M2 A1 and M2 A2**

1. Inspect the orange wire running from M2 A2 to M1 A2 for loose connections or damage. Repair or replace as necessary. Retest unit in the up direction. **Q-** Does the lift run? **No** go to **Trouble shooting Section 1, Step #24**

## Trouble Shooting- Section 3

### Lift will move but other functions are not working

**Problem: Lift moves 2” away from either the top or bottom landing and stops**

Both the Upper and Lower landing Interlocks must be in the locked position at all times in order for the lift to run.

1. **Q-** Is the upper gate door closed with the interlock in the locked position with the Barrel key? **No-** Go to next step **Yes-** Go to **Trouble Shooting Section 2- No Voltage at #2, Step #2.**
2. Use the barrel key to lock the upper gate interlock and then retest unit. **Q-** Does the lift run? **No-** proceed to **Trouble Shooting Section 2- No Voltage at #2, Step #2**

**Problem: Motor makes a noise but the lift does not move**

1. Remove the front cover panel from the lift in order to properly see the drive system including the motor, gearbox and drive nuts.
2. Perform an inspection of the drive nuts as per the **Drive Nut Safety Bulletin** included with the installation manual. Are the drive nuts in the correct position as per the **Drive Nut Safety Bulletin**? **Yes-** proceed to next step. **No-** Repair or replace the drive nuts as per factory instructions found at <http://www.trustram.com/maintBulletin.htm> -Replacement of Drive Nuts in TTL
3. Perform an inspection of the site and installation. Look for signs of the lift rubbing against the building, foreign objects restricting the travel of the unit, possible overloading of the unit etc. **Q-** Do any signs of this exist? **No-** Go to next step **Yes-** Remove or adjust as necessary and then retest the unit. **Q-** Does the lift run? **No-** Go to next step
4. Look at the gearbox output drive. **Q-** Is the main drive screw attached to the gearbox? **No-** Call RAM Manufacturing for tech support **Yes-** Go to next step
5. Look at the gearbox and motor and then try to run the motor. **Q-** Does the motor turn but the gearbox does not? **Yes-** Call RAM Manufacturing for tech support **No-** Go to next step
6. Have an electrician use a clamp on Amp meter to test for amperage draw on the motor when it is attempting to run. **Q-** Does the Amperage draw exceed 10 Amps? **Yes or No-** Call RAM Manufacturing for tech support

**Problem: Lift moves past landing when using call stations**

The wiring for the remote call stations (either toggle or push button remotes) has been mixed up between the upper and lower.

1. **Q-** Does the lift have push button remotes or toggle remotes? If the lift has push button remotes then go to **next step**. If lift has toggle remotes go to **Step #9**
2. Go to the outside junction box
3. On Cable 11 verify the lower remote call station (white and black pair) is wired to wire labels 141 and 142, the blue and orange pair. **Q-** Is the remote wired correctly? **Yes-** Go to next step, **No-** change the wires to reflect this nature and retest unit in the down direction using the remote. **Q-** Does the lift stop at bottom landing properly? **No-** Go to next step **Yes-** Go to **Step #6**
4. Go the main control box
5. On Cable 11 verify the blue wire is wired to terminal block 4 and the orange wire is wired to terminal block 5. Make sure the connections are clean with no loose wire strands touching any other terminals. **Q-** Are the wires wired correctly? **No-** Repair wire connections and retest unit in the down direction using the remote. **Q-** Does the lift stop at the bottom landing? **No-** Call RAM Mfg for further assistance. If the lift also has toggle remotes Go to Step #9
6. On Cable 11 verify the upper remote call station (red and yellow wires if lift has an upper gate or white and black if lift has remote call station box) is wired to wire labels 143 and 144, the white and red pair. **Q-** Is the remote wired correctly? **Yes-** Go to next step, **No-** change the wires to reflect this nature and retest unit in the up direction using the remote. **Q-** Does the lift stop at the top landing properly? **No-** Go to next step
7. Go to the main control box
8. On Cable 11 verify the white wire is wired to terminal block 4 and the red wire is wired to terminal block 6. Make sure the connections are clean with no loose wire strands touching any other terminals. **Q-** Are the wires wired correctly? **No-** Repair wire connections and retest unit in the up direction using the remote. **Q-** Does the lift stop at the top landing? **No-** Call RAM Mfg for further assistance. If the lift also has toggle remotes Go to next step.
9. Open the lower and upper toggles remote to verify the wiring inside. The white and black pair should be used for the down circuit and the green and red pair for the up circuit. **Q-** Is the remote wired this way? **Yes-** Go to next step **No-**

- Repair wire connections to reflect the above and retest unit in both directions using the remotes. **Q-** Does the lift stop at the bottom and top landing properly? **No-** Go to next step
10. On Cable 11 verify the lower remote call circuit from the toggle(s) (white and black pair) is wired to wire labels 141 and 142, the blue and orange pair. **Q-** Is the remote wired correctly? **Yes-** Go to next step, **No-** change the wires to reflect this nature and retest unit in the down direction using the remote. **Q-** Does the lift stop at bottom landing properly? **No-** Go to next step **Yes-** Go to **Step #13**
  11. Go the main control box
  12. On Cable 11 verify the blue wire is wired to terminal block 4 and the orange wire is wired to terminal block 5. Make sure the connections are clean with no loose wire strands touching any other terminals. **Q-** Are the wires wired correctly? **No-** Repair wire connections and retest unit in the down direction using the remote. **Q-** Does the lift stop at the bottom landing? **No-** Call RAM Mfg for further assistance.
  13. On Cable 11 verify the upper remote call circuit from the toggle(s) (red and yellow pair) is wired to wire labels 143 and 144, the white and red pair. **Q-** Is the remote wired correctly? **Yes-** Go to next step, **No-** change the wires to reflect this nature and retest unit in the up direction using the remote. **Q-** Does the lift stop at the top landing properly? **No-** Go to next step
  14. Go to the main control box
  15. On Cable 11 verify the white wire is wired to terminal block 4 and the red wire is wired to terminal block 6. Make sure the connections are clean with no loose wire strands touching any other terminals. **Q-** Are the wires wired correctly? **No-** Repair wire connections and retest unit in the up direction using the remote. **Q-** Does the lift stop at the top landing? **No-** Call RAM Mfg for further assistance.

## Appendix A

Parts breakdown of Trus<T>Lift with Upper and Lower Interlocks

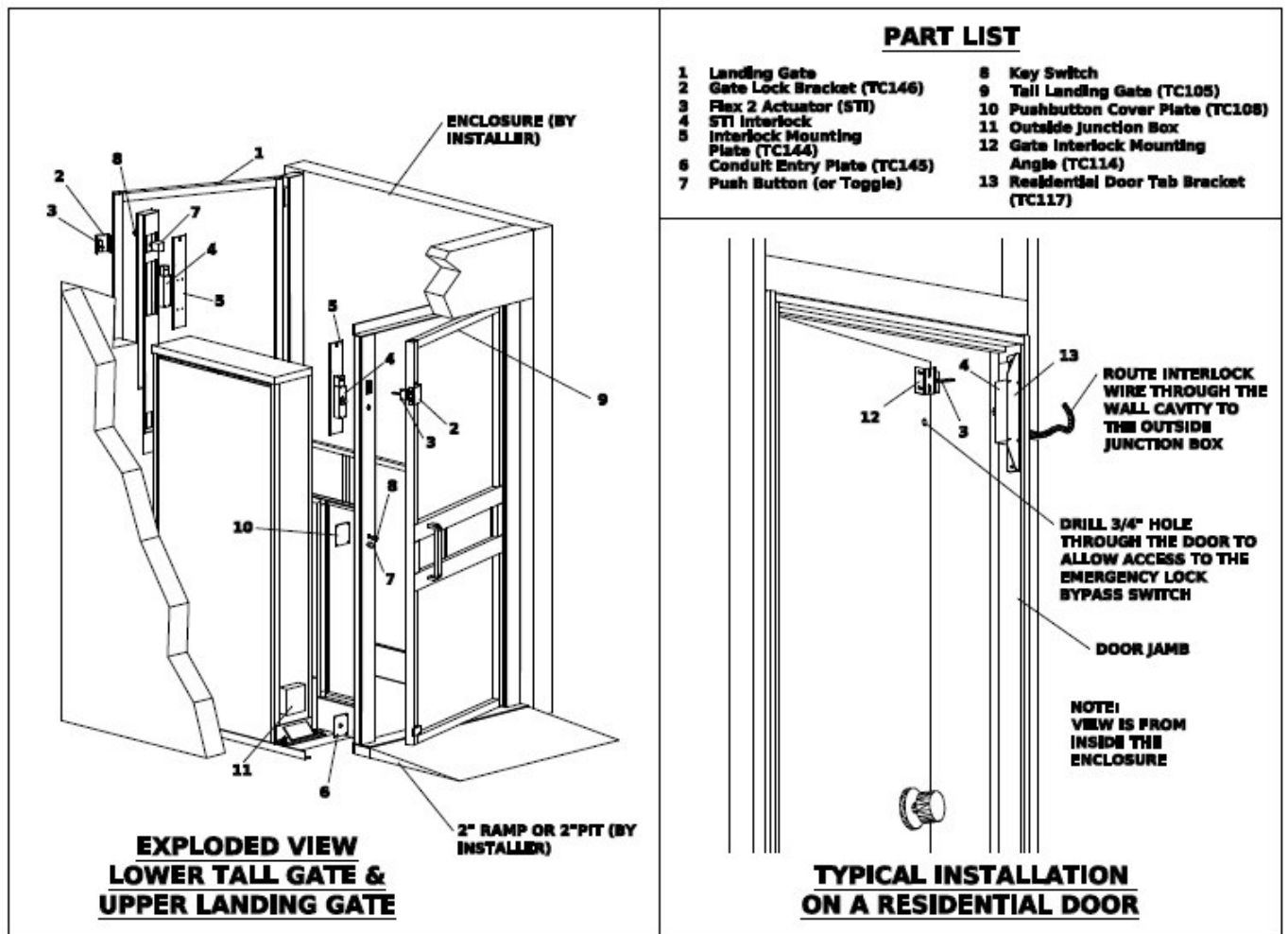

Appendix B

Limit Switch activation drawing- the following drawing shows the limit switches being activated along with a description of what their function is.

